

Sample Champion - Application note # 17

Impedance measurement: practical construction of the connector

This application note describes the construction of the connectors for using the Sample Champion Impedance Plugin (see **Application note #16**).

The plugin accepts two different configurations for the connection of the device under test (loudspeaker).

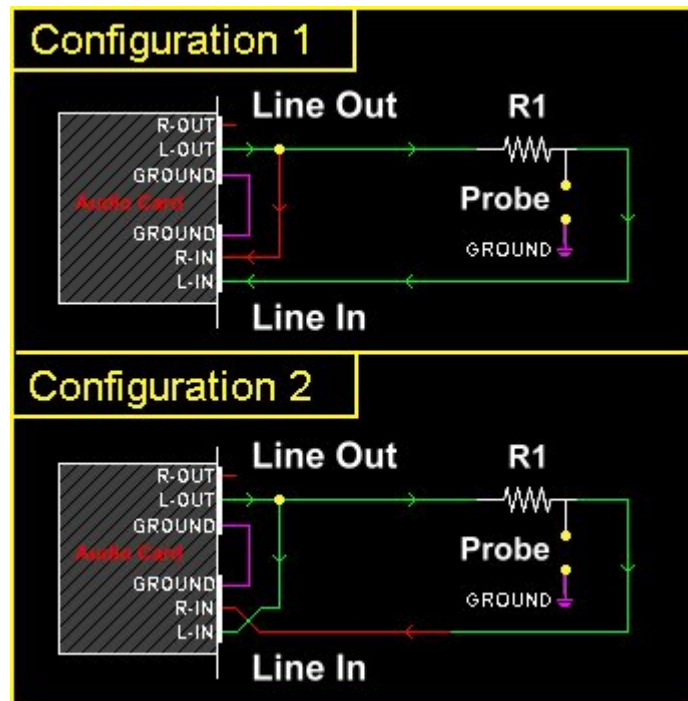

Allowed configurations

Basically, one channel output is connected directly to one channel input and the other one measures the impedance by means of a simple partitive network.

Another way of describing it is reported in the following scheme:

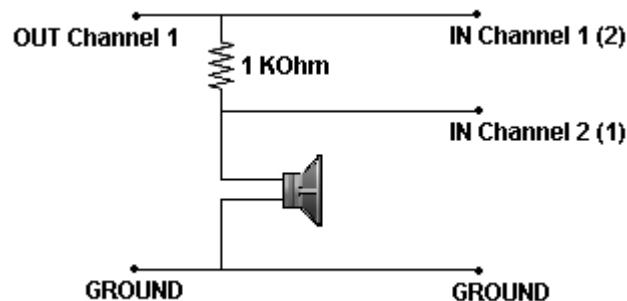

The following examples refer to the first configuration in the plugin.

Assuming a soundcard with female minijack connectors for **Line input** and **Line output**, the following example requires:

- 2 common stereo minijack-RCA cables



- 3 RCA male connectors and 3 adapters female RCA-female RCA or 3 female RCA connectors

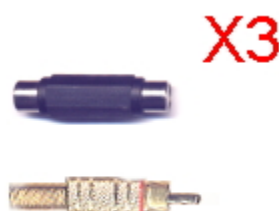

The impedance measurement connector can be assembled as shown in the following figure:

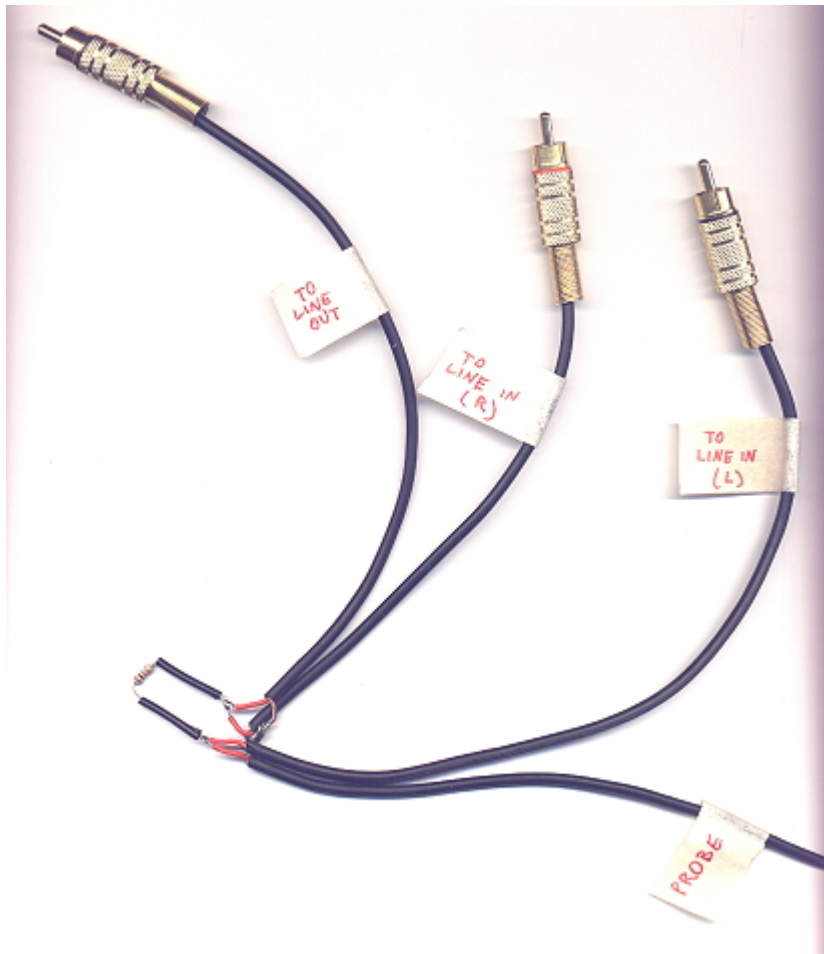

Impedance measurement connector

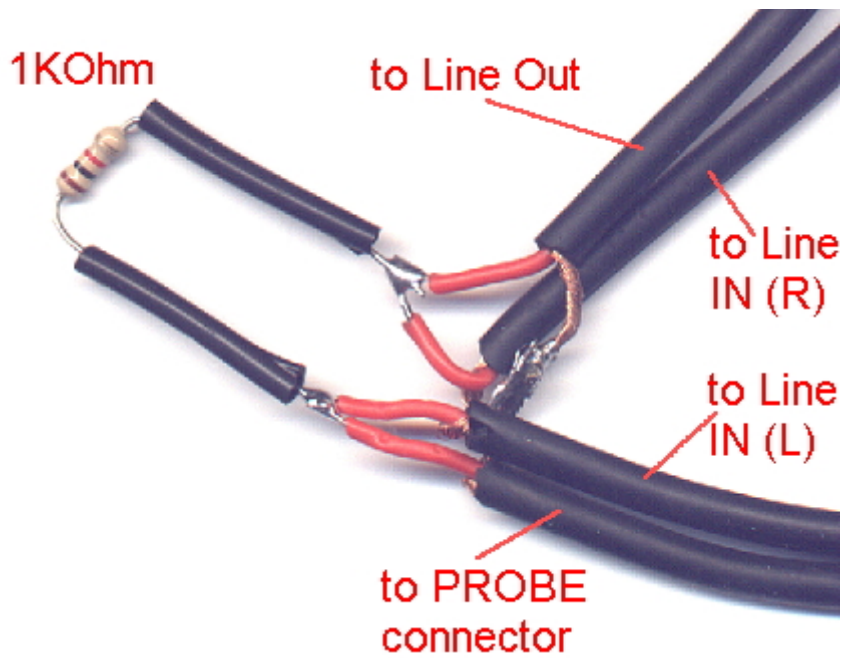

Zooming of the above figure

Note that all grounds are connected together. Then the 2 minijack-RCA cables must be connected to **Input** and **Output** of the soundcard and to the above connector as shown in the following figures

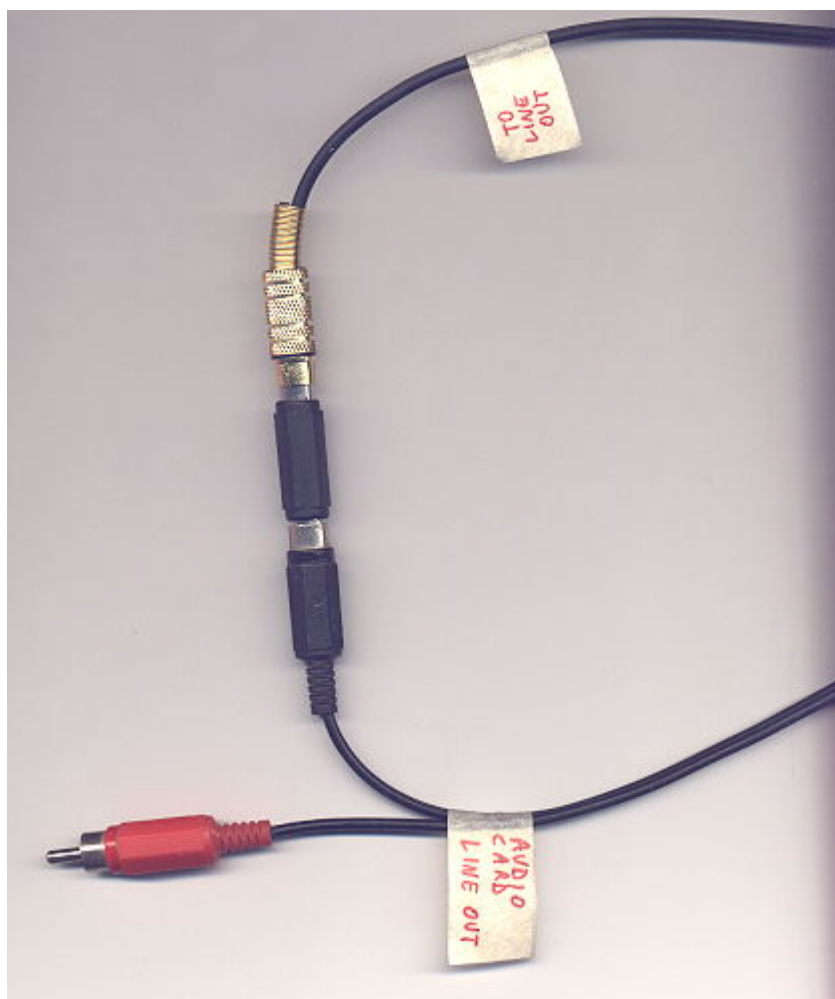
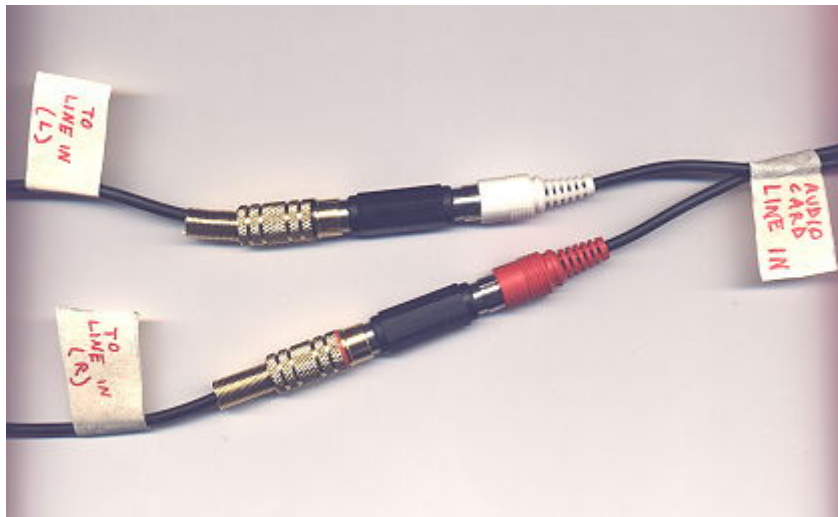

Alternatively the connector can be assembled starting from a minijack connector. The following figure shows a minijack.

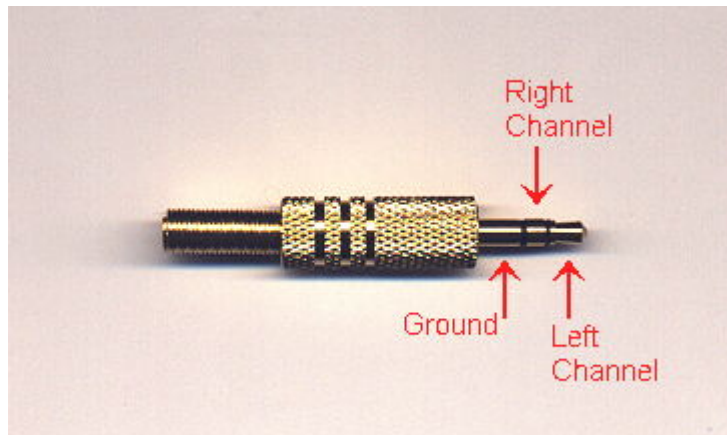

Another possible construction scheme, using a box, is shown in the following figure:

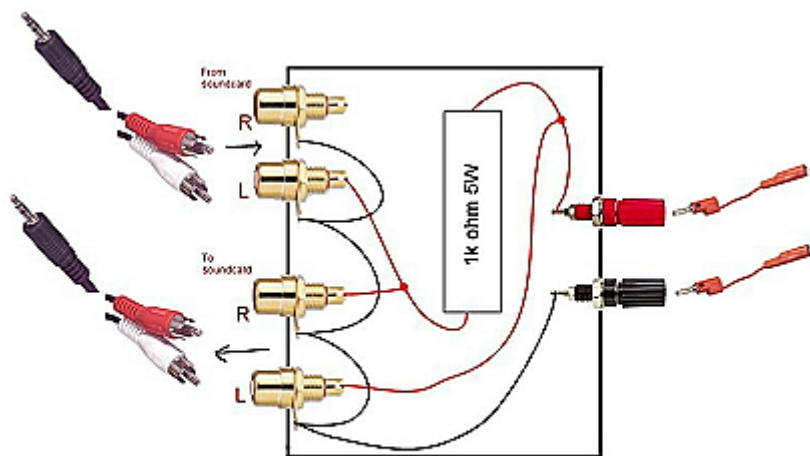

Thanks to Ellen Tunstall for this scheme

